

Instructions for Use

3.0 T 16Ch Diagnostic Breast Coil

to be operated on

GE 3.0 T MR Systems

Important Document: Read Carefully and Keep in a Safe Place

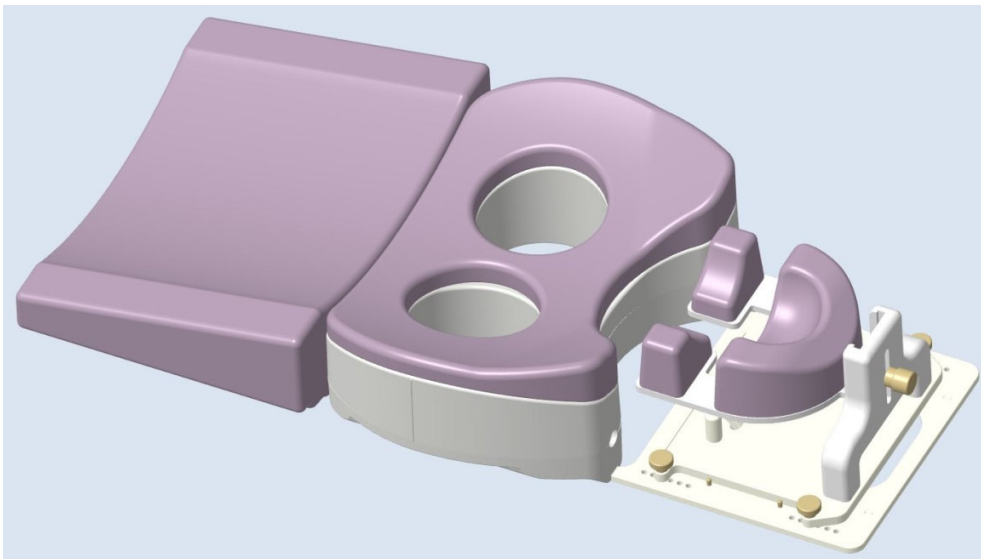

CE

RAPID Biomedical GmbH

Manufacturer:

RAPID Biomedical GmbH

Kettelerstrasse 3-11

97222 Rimpar, Germany

Tel.: +49 (0)9365-8826-0

Fax: +49 (0)9365-8826-99

info@rapidbiomed.de

www.rapidbiomed.de

© 2021-02-03 RAPID Biomedical GmbH

Document Edition: 4.0

Technical changes reserved.

Table of Contents

Part I	General Instructions	5
1	Instructions for Use	6
1.1	<i>Instructions for Use</i>	6
1.2	<i>Symbols</i>	6
1.3	<i>Copyright</i>	6
1.4	<i>Limitation of Liability</i>	6
1.5	<i>Provision of Instructions for Use</i>	7
2	Handling	8
2.1	<i>Device Sensitivity</i>	8
2.2	<i>Maintenance</i>	8
2.3	<i>Storage</i>	8
2.4	<i>Disposing of Old Devices</i>	8
2.5	<i>Returning of devices</i>	8
2.6	<i>Environmental Protection</i>	9
3	General Safety Instructions	10
3.1	<i>General Information</i>	10
3.2	<i>Area of Use</i>	11
3.3	<i>Dangers of RF Transmit Coils</i>	11
4	Error Case	12
4.1	<i>Indication of Error</i>	12
4.2	<i>Error Condition</i>	12
Part II	Product Information	13
5	Device Description	14
5.1	<i>Indications for Use, Contraindications, Environment</i>	14
5.2	<i>Scope of Delivery</i>	14
5.3	<i>Device Overview</i>	15
6	Initial Operation and Recommissioning	16
6.1	<i>General Instructions</i>	16
6.2	<i>SAR Monitoring</i>	16
7	Regular Use	17
7.1	<i>Positioning the Device</i>	17
7.2	<i>Positioning the Patient</i>	20
7.3	<i>Connecting to the MR System</i>	22

7.4	<i>Disconnecting the Coil</i>	23
7.5	<i>Cleaning and Disinfection</i>	24
8	Special Technical Instructions for Using the Device	25
8.1	<i>Performance / Quality Assurance</i>	25
9	Appendix	26
9.1	<i>Specifications</i>	26
9.2	<i>Regulatory Information</i>	28
9.3	<i>Labeling</i>	29
9.4	<i>Symbols Glossary</i>	31
9.5	<i>List of Acronyms</i>	33

Part I General Instructions

1 Instructions for Use

1.1 Instructions for Use

The Instructions for Use are part of the above-mentioned product of RAPID Biomedical GmbH (RAPID Biomedical). It is meant for individuals who operate, install or commission this product. Before working with this product, it is essential to read the Instructions for Use carefully. Consult RAPID Biomedical in case you do not understand parts of the Instructions for Use. The Instructions for Use have to be made available to all users of the product at all times during its lifetime. The Instructions for Use have to be passed on to any subsequent owner/user of the product.

1.2 Symbols

Product Safety Signs and Labels are described as follows.

⚠ CAUTION
Indicates a hazardous situation that, if not avoided, could result in minor or moderate injury.

CAUTION consists of the following elements:

Situation	<i>Information about the nature of a hazardous situation.</i>
Hazard	<i>Consequences of not avoiding a hazardous situation.</i>
Prevention	<i>☞ Methods of avoiding a hazardous situation.</i>

NOTICE
Indicates important information considered to notify people on hazards that could result in things other than personal injury.

NOTICE consists of the following elements:

Situation	<i>Information about the nature of a hazardous situation.</i>
Hazard	<i>Consequences of not avoiding a hazardous situation.</i>
Prevention	<i>☞ Methods of avoiding a hazardous situation.</i>

	Indicates useful advice or recommendations.
---	--

1.3 Copyright

Unauthorized copy of the Instructions for Use in whole or in part is an infringement of RAPID Biomedical's copyright.

1.4 Limitation of Liability

The specifications and data contained in the Instructions for Use were correct at the time of going to press. RAPID Biomedical does not accept liability and is also exempted from all claims by third parties arising from damage incurred with the device due to inappropriate or unauthorized use, operational errors or disregarding the Instructions for Use, especially the safety instructions contained herein. The warranty and liability conditions contained in the Standard Terms and Conditions (AGB) of RAPID Biomedical are not affected.

1.5 Provision of Instructions for Use

- **CD-ROM:** A CD with electronic Instructions for Use in different languages is being delivered together with the product. For further information refer to the eIFU Leaflet;
- **Download:** Electronic Instructions for Use can be downloaded in different languages and all available versions from the RAPID Biomedical Website - www.rapidbiomed.de;
- **Instructions for Use in paper form or on CD:** Instructions for Use in paper form or on CD can be ordered at RAPID Biomedical free of charge via email (see email address on page 2). Unless ordered differently, always the latest version will be delivered within 7 days after receipt of order. For available languages refer to the eIFU Leaflet.

2 Handling

2.1 Device Sensitivity

NOTICE	
Situation	Sensitive electronic device, not handled with care.
Hazard	Device can be damaged.
Prevention	<ul style="list-style-type: none"> ☞ Handle and use with appropriate care. ☞ Avoid jolts or impacts which can affect the device. ☞ Only carry the device on its housing. ☞ Treat any attached cables and plugs with due care and do not use them for carrying the device.

⚠ CAUTION	
Situation	Carrying the device by cables and/or plugs.
Hazard	Device and/or other equipment can be damaged.
Prevention	<ul style="list-style-type: none"> ☞ Do not carry the device by its cables and/or plugs. ☞ Carry the device by its handles or by lifting the main body. ☞ Handle the device with care.

2.2 Maintenance

No maintenance is required if the device is used properly and cleaned regularly.

2.3 Storage

Store the device away from potential sources of contamination and mechanical impacts in a dry cool place which is not subject to strong variations in temperature (see 9.1 Specifications).

2.4 Disposing of Old Devices

RAPID Biomedical hereby confirms that its devices conform to the guidelines, regulations and laws of the European Union concerning the disposal of waste electrical and electronic equipment in its latest version (see 9.3 Labeling).

NOTICE	
Situation	Inproper disposal.
Hazard	Environmental hazard.
Prevention	☞ This device must not be disposed of as domestic waste. Send the old device for disposal to the manufacturer (find address on page 2).

	RAPID Biomedical accepts the return of packaging material and of old device.
---	--

2.5 Returning of devices

RAPID Biomedical ships its products in dedicated packaging which can be reused several times. Returning of devices is handled by the distributor. Contact your local service representative accordingly.

NOTICE	
Situation	Inadequate packaging and/or improper means of transport.
Hazard	Device can be damaged.
Prevention	☞ The original packaging is supposed to be used for returning the product.

2.6 Environmental Protection

RAPID Biomedical assures it will observe the environmental-protection regulations of the applicable EU Directives over the entire life cycle of its devices from development through manufacturing and disposal (see also 9.3 Labeling).

3 General Safety Instructions

3.1 General Information

Proper and safe operation of the 16Ch Diagnostic Breast Coil in combination with the MR System requires technical knowledge of the operating personnel and a high degree of familiarity with this Instructions for Use and the Instructions for Use of the MR System.

⚠ CAUTION	
Situation	Maloperation of the device during installation, operation, service and/or repair.
Hazard	Patient and/or user can be harmed, device and/or other equipment can be damaged.
Prevention	<ul style="list-style-type: none"> ☞ The device may only be installed by authorized personnel. ☞ The device may only be operated by trained personnel. ☞ It is mandatory to follow this Instructions for Use closely. ☞ Follow the Instructions for Use of the MR-System, additional devices and facilities.

⚠ CAUTION	
Situation	Defective medical device.
Hazard	Patient and/or user can be harmed, device and/or other equipment can be damaged.
Prevention	<ul style="list-style-type: none"> ☞ The operational reliability of the device must be checked and ensured prior to each use. ☞ If the device is defective, it must not be used.

Checking the operational reliability of the device includes checking the housing, checking the connections (cables, plugs) and checking all labels (9.3 Labeling). The same applies to all the other devices required for operation and the accessories being used.

The local service representative must be notified immediately in the event of damage or malfunction. Missing or damaged labels may only be amended or replaced by the service representative. Only a representative authorized by RAPID Biomedical is entitled to repair or alter this product. See Chapter 4 Error Case.

When initially operated and prior to first use on a live test object, proper function of the device must be verified and documented by a test on an appropriate MR phantom (8.1 Performance / Quality Assurance).

⚠ CAUTION	
Situation	Disturbed signal detection by low SNR or image artefacts.
Hazard	Patient and/or user can be harmed, device and/or other equipment can be damaged.
Prevention	<ul style="list-style-type: none"> ☞ Proper function of the device has to be checked and ensured prior to each use. ☞ The device is not to be used if failure of proper function is detected. ☞ The device may only be operated by trained personnel.

	For EU Member States only: Any serious incident that has occurred in relation to the device should be reported to the manufacturer and the competent authority of the state in which the user and/or patient is established.
---	--

	<p>Prescription Use only – “Rx only”</p> <p>Country specific laws restrict this device to sale by or on the order of a physician, or with the descriptive designation of any other practitioner licensed by the law of the country in which he practices to use or order the use of the device. This device may only be distributed to persons who are licensed practitioners or to persons who have a prescription or other order from a licensed practitioner to purchase it.</p>
---	--

3.2 Area of Use

The device has been developed for use in conjunction with the MR System indicated in 5 Device Description.

	<p>The EC Declaration according to Article 12 of Directive 93/42/EEC [Article 22 of Regulation (EU) 2017/745] stipulates that the device may only be used in combination with the specified devices. Use of the device in combination with other non-listed devices is regarded as off-label-use and disregard of the Intended Use. This leads to the loss of warranty.</p>
---	---

⚠ CAUTION

Situation	The device is not operated according to Intended Use.
Hazard	Patient and/or user can be harmed, device and/or other equipment can be damaged.
Prevention	☞ The device is to be used according to its Intended Use only.

	<p>Follow the instructions in the manual for the MR System, as well.</p>
---	--

3.3 Dangers of RF Transmit Coils

⚠ CAUTION

Situation	<p>The device is operated without considering its transmit functionality, e.g:</p> <ul style="list-style-type: none"> ○ Electrically conductive materials are located within the working range of the device. ○ There is a Skin-to-skin contact of different parts of the body. ○ Skin is in direct contact with the device including the cables. ○ Cables form a closed high frequency loop. ○ The connecting cables are located in the RF field of the device. ○ There are loops in the RF or ECG leads. ○ ECG electrodes and cables not approved for MR examinations are being used. ○ Devices, (receive) coils or cables are disconnected while operating the device.
Hazard	Patient can experience excessive heating and/or can suffer RF burns.

⚠ CAUTION	
Prevention	<ul style="list-style-type: none"> ☞ Remove metallic items. ☞ Check/correct the position/posture of the patient to avoid loops (especially feet and arms). ☞ Prevent direct contact between the skin and the device. Ensure there is a gap between the patient and the surface of the device including the cables. ☞ Check/correct the cable guiding. Prevent / untangle looping when routing the cables. ☞ Make sure the cable is not routed in the RF field of the device. ☞ Prevent / untangle looping when routing RF and/or ECG leads. ☞ Only use accessories approved or provided by the manufacturer of the MR device. ☞ Remove disconnected devices, coils or cables prior to the examination.

4 Error Case

4.1 Indication of Error

The device has no error indicators. Operators have to rely on other means of error indication. In this regard they should:

- constantly observe the error information provided by the MR system
- regularly check on the functionality of the device (e.g. for unexpected examination results, for degraded MR image quality, etc.)

4.2 Error Condition

Ensure that the product is setup and used according to the applicable Instructions for Use. Contact your local service representative for assistance in any other case.

⚠ CAUTION	
Situation	Damaged or malfunctioning device.
Hazard	Patient and/or user can be harmed, device and/or other equipment can be damaged.
Prevention	☞ The device must not be used in the event of damage and/or malfunction. Notify your local service representative immediately.

⚠ CAUTION	
Situation	Unauthorized repair of a damaged or malfunctioning device.
Hazard	Patient and/or user can be harmed, device and/or other equipment can be damaged.
Prevention	☞ Only a representative authorized by RAPID Biomedical is entitled to repair the device.

Part II Product Information

5 Device Description

The 16Ch Diagnostic Breast Coil (3.0 T 16Ch Diagnostic Breast Coil) is designed for use with a magnetic resonance (MR) system. The coil is designed to work in unison with the Body Coil (BC) of the MR system, which will excite the hydrogen (1H) nuclei with radio frequency (RF) magnetic fields, so that the coil may receive the resultant RF signal from the excited nuclei. The coil is designed as a receive-only coil for high resolution MR examination of breast.

The coil housing features a curved surface for better adaption to the anatomical region of interest. The coil is receive-only (Rx) and consists of 16 independent single loop coil elements with integrated low noise preamplifiers and a connector to the GE 3.0 T MR Systems. The coil is fixed tuned and matched to the typical load of a breast at the Larmor frequency of 1H at 3.0 T (127.7 MHz). Decoupling circuits are integrated in each single loop element providing a decoupling from the Body Coil of the MR System during transmission of the RF excitation pulse. The coil provides both, unilateral and bilateral images (Left, Right and Both) of the anatomy of interest.

5.1 Indications for Use, Contraindications, Environment

Indications for Use / Intended Purpose	The 16Ch Diagnostic Breast Coil is indicated for use as diagnostic imaging device extension for GE 3.0 T MR Systems to produce transverse, sagittal, coronal and oblique images, spectroscopic images and/or spectra, displaying the internal structure of the breast. These images when interpreted by a trained physician, yield information that may assist in diagnosis.
Contraindications	The 16Ch Diagnostic Breast Coil does not alter the contraindications for the GE 3.0 T MR Systems.
Application	Breast
Applied Parts	Coil enclosure and all cushions
MR System	GE 3.0 T MR Systems
Field Strength B_0	3.0 T
Operation of 1H Body Coil	necessary (1H excitation)

5.2 Scope of Delivery

The following components are supplied with this device:

For GE 3.0 T MR Systems

- 3.0 T 16Ch Diagnostic Breast Coil (GEHC part #5772248-2)
- 16Ch Diagnostic Breast Head Rest
- 16Ch Diagnostic Breast Comfort Pad
- 16Ch Diagnostic Breast Ramp Pad
- eIFU Leaflet
- CD containing electronic Instructions for Use in different languages

5.3 Device Overview

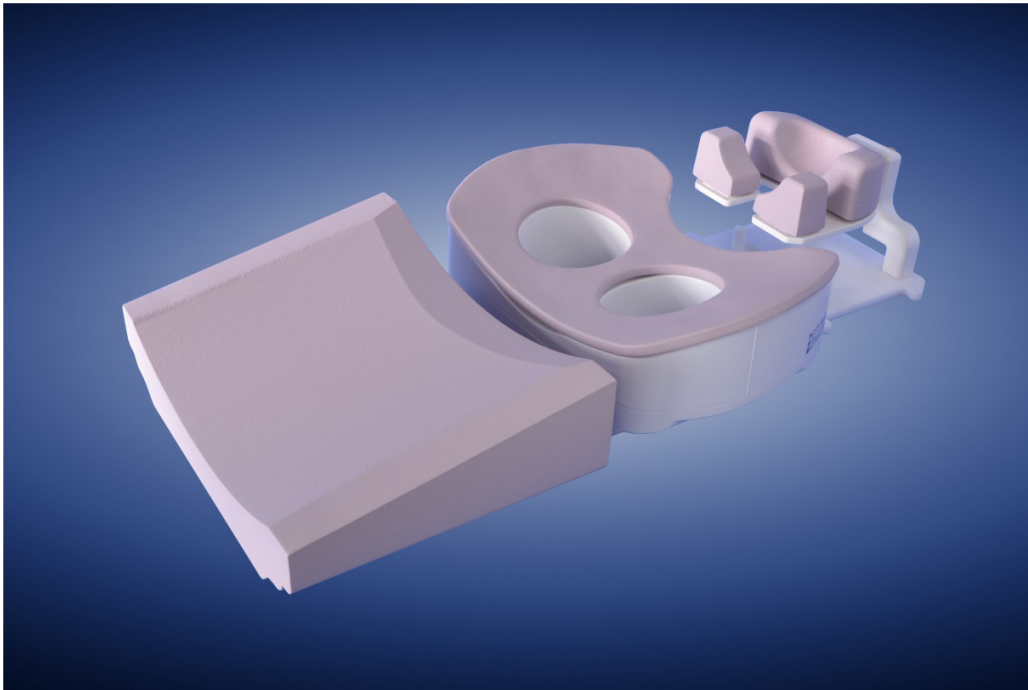

Figure 1: Sample for 16Ch Diagnostic Breast Coils

6 Initial Operation and Recommissioning

6.1 General Instructions

Before initial operation after delivery, service or repair, always check the operational reliability of the device.

NOTICE	
Situation	Device is operated before acclimatised.
Hazard	Damage of medical device by condensed water.
Prevention	<ul style="list-style-type: none"> ☞ Installation and initial operation of the device may only take place after a reasonable period of acclimatisation. Store the unpackaged device in the environment intended for later operation for 24 hours before operation. ☞ See Attachment 9.1 Specifications for the permissible environment for operating the device.

6.2 SAR Monitoring

The device does neither feature separate monitoring of the specific absorption rate (patient protection) nor maximum applied rms RF power (component protection, see 9.1 Specifications). This is done by the MR System by monitoring and limiting maximum rms RF power during scans.

The maximum rms RF power is coil dependent and defined in the coil configuration file of the MR System. Input for calculating the correct applied SAR is coil related parameters defined by RAPID in the coil configuration file as well as patient related parameters entered into the user interface when registering a patient.

To ensure that SAR control works properly, the coil is encoded and recognized by the MR System when plugged. When plugging the coil, the MR System recognizes this incident and sets related parameters given in the corresponding configuration file. By this mechanism, patient and coil are kept safe from being harmed/ destroyed.

⚠ CAUTION	
Situation	Examinations with the device not connected according to this Instructions for Use.
Hazard	Patient and/or user can be harmed, device and/or other equipment can be damaged.
Prevention	<ul style="list-style-type: none"> ☞ The device has to be connected as specified in this Instructions for Use. ☞ Follow the connecting instructions given in the Instructions for Use of the MR System. ☞ Prior to examinations make sure all connections have been completed. ☞ Proper connection between the coil and the MR System needs to be checked in the user interface of the software prior to each exam. ☞ Examinations are not to be performed if the coil is inside the magnet and disconnected from the MR System. Do not perform any examination with a disconnected device.

7 Regular Use

7.1 Positioning the Device

Position the 16Ch Diagnostic Breast Coil (a) on the patient table of the GE MR-System together with the head rest (b), the comfort pad (c) and the ramp pad (d). Refer to the picture in the following, which is applicable to the existing GE MR-System.



Note that the 16Ch Diagnostic Breast Coil has to be positioned with the head rest facing away from the MR-System and the ramp pad facing towards the MR-System.

GE MR-Systems with **GEM table**, e.g.
 GE Discovery MR750w - GE SIGNA Architect:

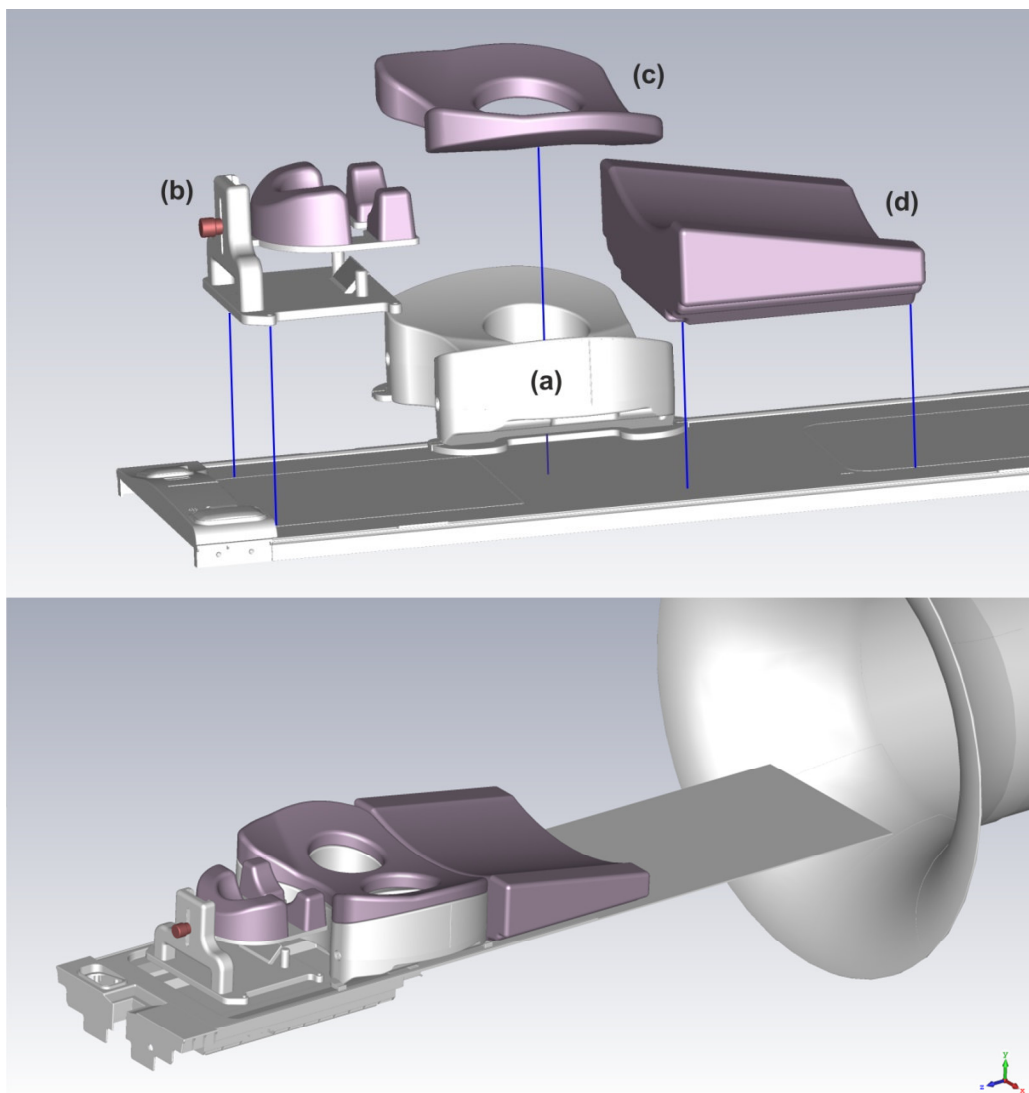

Figure 2: 16Ch Diagnostic Breast Coils' setup on a GE MR-System with GEM patient table, consisting of the breast coil (a), the head rest (b), the comfort pad (c) and the ramp pad (d).

GE MR-Systems with **non-GEM table**, e.g.
GE Discovery MR750 – GE Discovery MR750w:

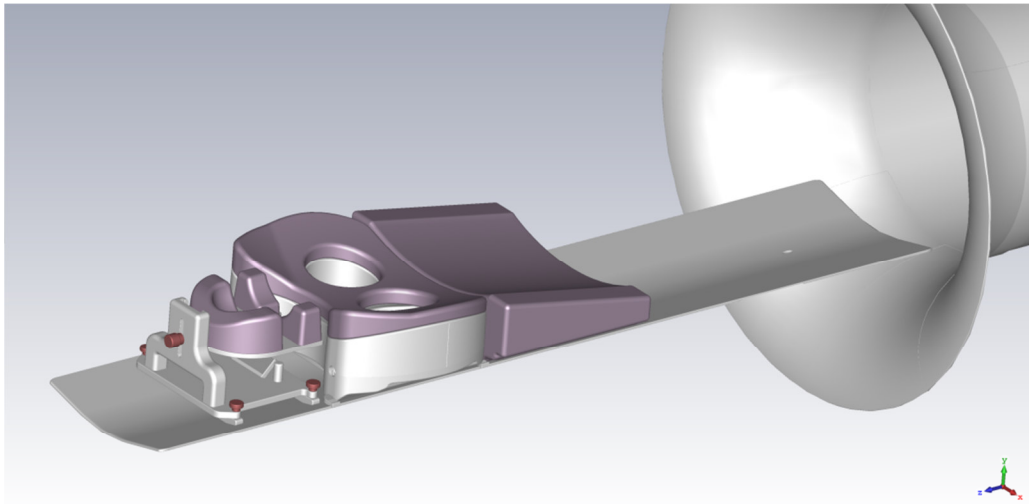

Figure 3: 16Ch Diagnostic Breast Coils' setup on a GE MR-System with non-GEM patient table.

GE MR-Systems with **wide table**, e.g.
GE SIGNA Pioneer - GE SIGNA Premier MR-Systems:

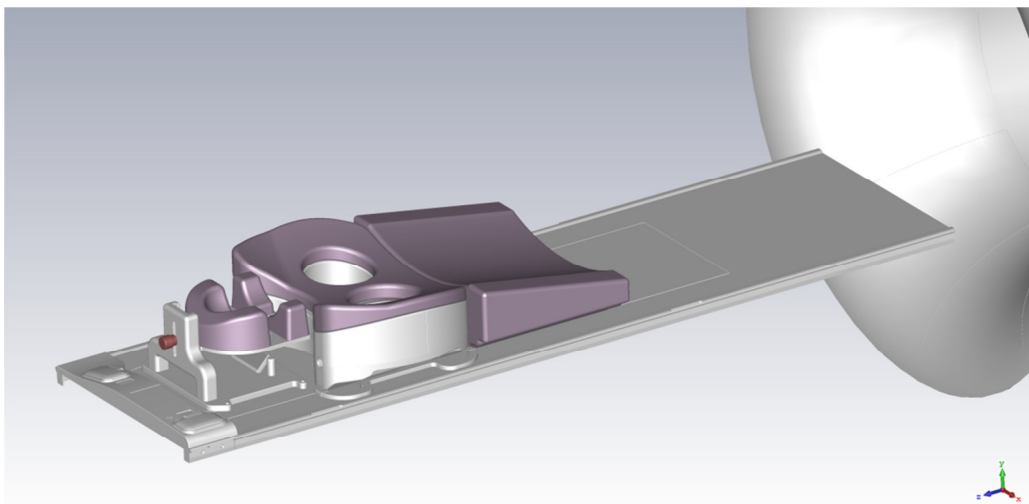

Figure 4: 16Ch Diagnostic Breast Coils' setup on a GE MR-System with wide patient table.

GE SIGNA PET/MR Systems:

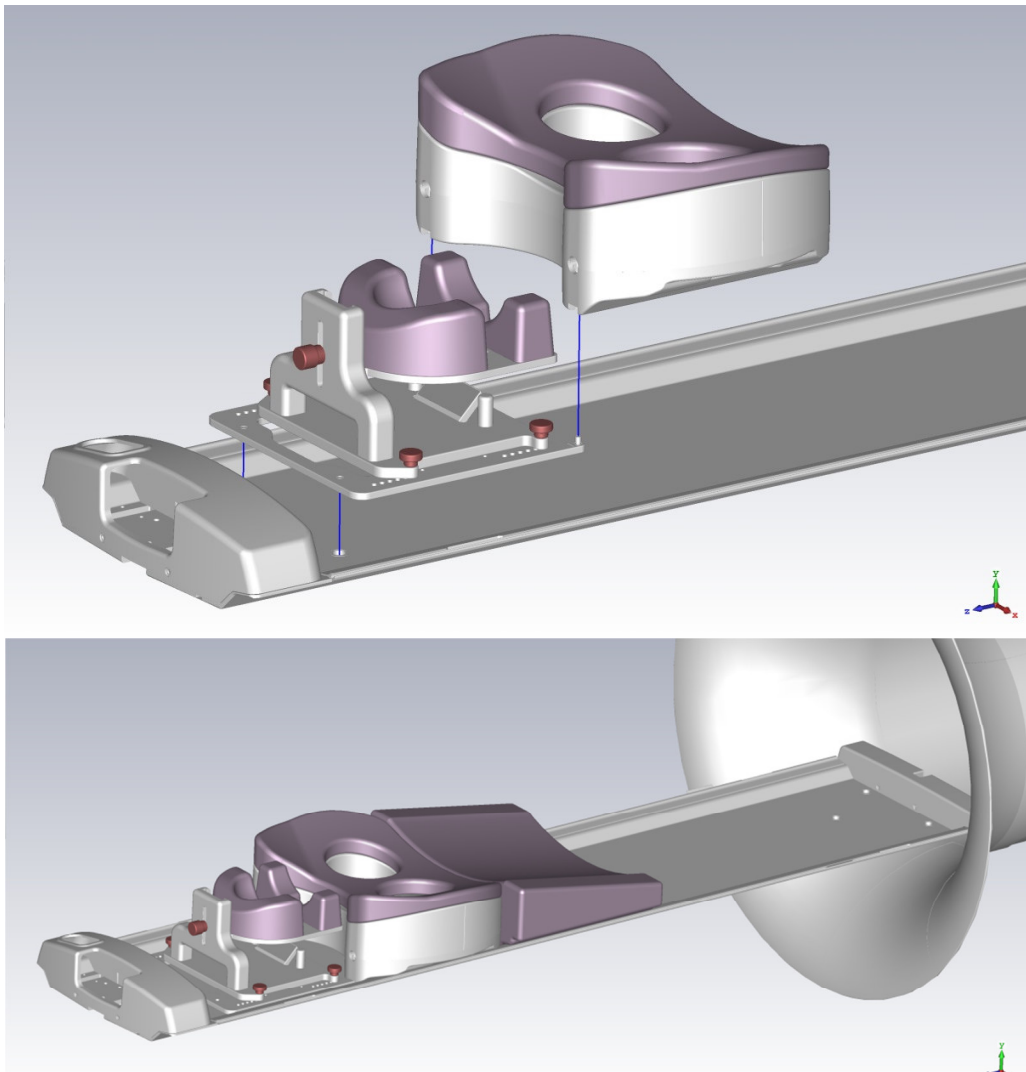

Figure 5: 16Ch Diagnostic Breast Coils' setup on a GE PET/MR System.

When setting up the product on the patient table, ensure that the positioning knobs on the underside of the head rest's frame are inserted into the positioning recesses at the foot end of the patient table. This way, undesired movement of the head rest is prevented. Position the 16Ch Diagnostic Breast Coil on the patient table that its positioning pegs on the underside of the coil housing are inserted into the loop ends of the head rest's frame. Undesired movement of the coil is prevented this way.

⚠ CAUTION	
Situation	PET signal is attenuated by the device.
Hazard	PET signal attenuation correction (AC) will be incorrect which can lead to wrong diagnostic results.
Prevention	<ul style="list-style-type: none"> ☞ Always apply a PET attenuation correction. ☞ Follow instructions given here for positioning the device in the correct location with respect to the PET detector rings.

7.2 Positioning the Patient

Position the patient feet first, prone onto the 16Ch Diagnostic Breast Coil.

1. The head rest, the comfort pad and the ramp pad should be used for patient comfort.
2. The patient's torso should be positioned on the coil so that each breast (or the breast of interest) is centered in the coil's left and/or right cavities.
 - a. Make sure that the patient is positioned in head-foot direction with the breast(s) directly over the cavities.
 - b. Ensure that the breast(s) fall freely and unhindered into the cavities.
 - c. Recheck on patient positioning if a unnaturally formed breast is seen on the scout images
3. It is recommended to position the arms alongside the patient (arms-down position).
4. Adjust the position of the head rest for a comfortable resting position of the patient's head and neck.

Refer to the picture in the following, which is applicable to the existing GE MR-System:

*GE MR-Systems with **GEM** table, e.g.
GE Discovery MR750w - GE SIGNA Architect:*

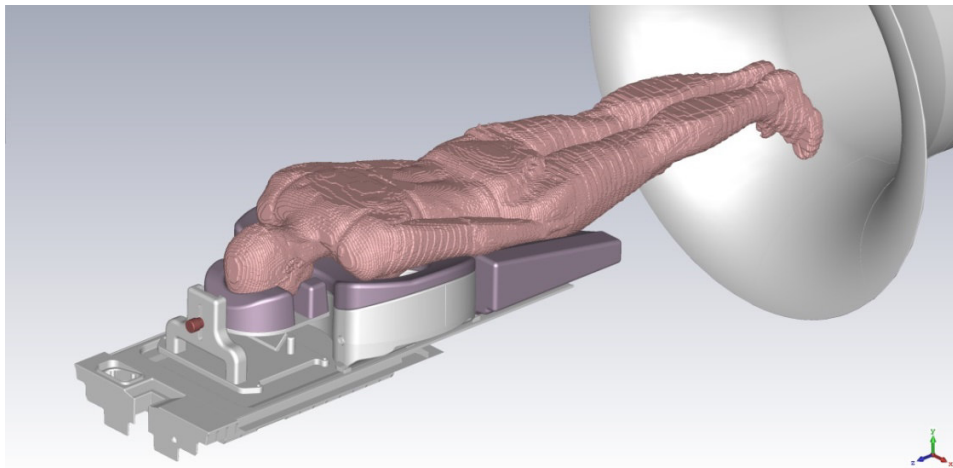

Figure 6: 16Ch Diagnostic Breast Coils' setup on a GE MR-System with GEM patient table.

*GE MR-Systems with **non-GEM** table, e.g.
GE Discovery MR750 – GE Discovery MR750w:*

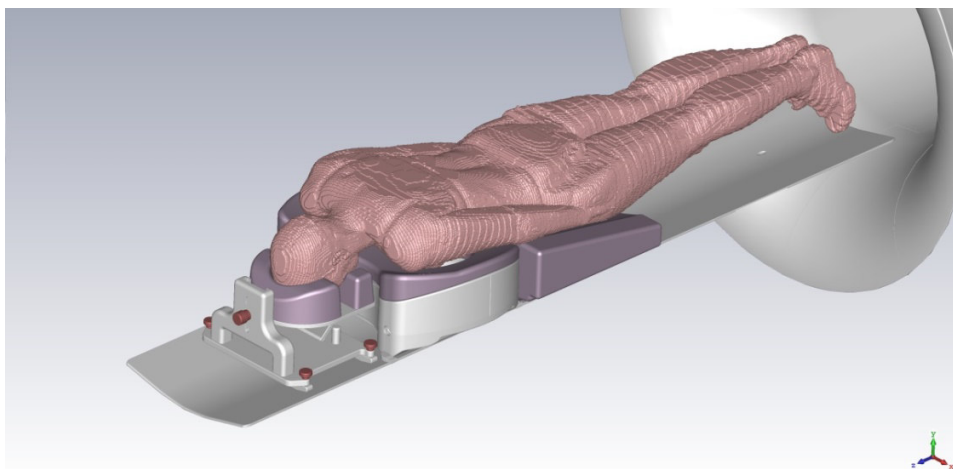

Figure 7: 16Ch Diagnostic Breast Coils' setup on a GE MR-System with non-GEM patient table.

GE MR-Systems with **wide table**, e.g.
GE SIGNA Pioneer - GE SIGNA Premier MR-Systems:

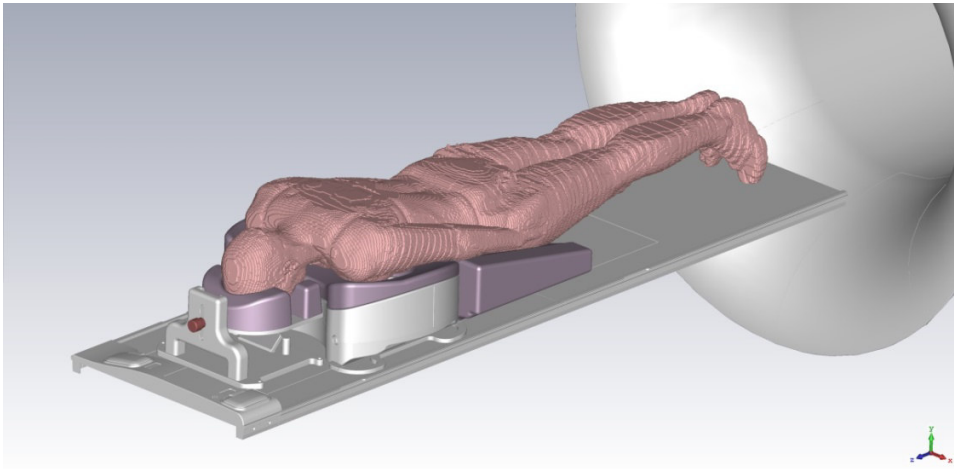

Figure 8: 16Ch Diagnostic Breast Coils' setup on a GE MR-System with wide patient table.

GE SIGNA PET/MR Systems:

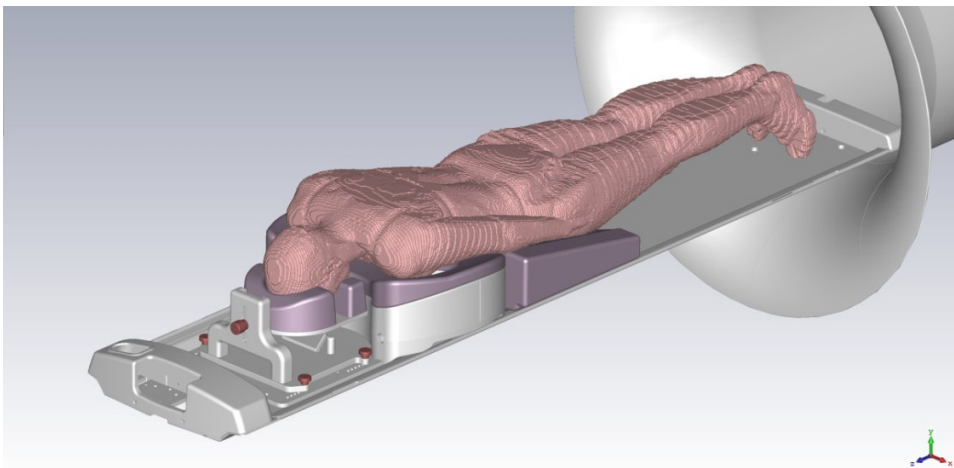

Figure 9: 16Ch Diagnostic Breast Coils' setup on a setup on a GE PET/MR System.

Position the patient in the iso-center of the MR System

1. Use the position aids molded into the sides of the coil housing to align the device with the laser alignment lights for patient land marking
2. Drive the patient table carefully into the MR System

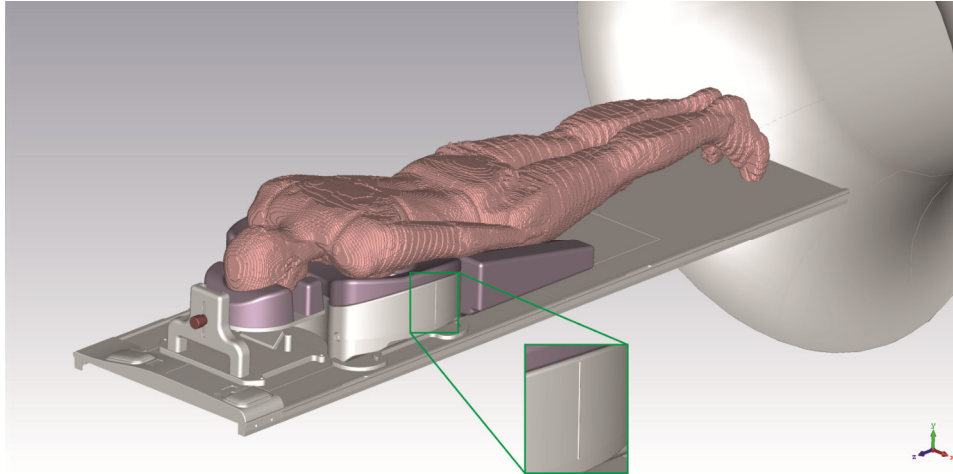

Figure 10: 16Ch Diagnostic Breast Coils' positioning aids molded into the coil housing.

⚠ CAUTION	
Situation	Long lasting direct contact between the device and patient skin.
Hazard	Skin irritation.
Prevention	☞ Avoid direct contact between the patient and the device, e.g. by using suitable pads or cloths.

Long lasting direct contact between the device and patient skin can lead to perspiration. Sweat is electrically conducting which means that RF power can be absorbed in usually non-conducting materials.

⚠ CAUTION	
Situation	Long lasting direct contact between the device and patient skin.
Hazard	RF burning.
Prevention	☞ Avoid direct contact between the patient and the device, e.g. by using suitable pads or cloths.

7.3 Connecting to the MR System

The 16Ch Diagnostic Breast Coil is equipped with one connecting cable terminating in a GE P-Port connector. This connector has to be plugged into socket 4 at the foot end of the patient table. Socket number 1 and 2 cannot be used.

Ensure that GE P-Port connector is locked after being plugged into socket 4.

The coil will be recognized and displayed on the in-Room Operator Console (iROC) of the MR system after connection.

Check the Coils' Tab on the user interface of the GE MR-System before starting an MR examination. Select the 16Ch Diagnostic Breast Coil from the Coil Components list and the desired coil configuration from the Coil Configuration list.

The coil is not correctly connected to the MR System if the coil is not shown in the Coil Components list. Any examination is prohibited in such case.

⚠ CAUTION	
Situation	Examinations with the device not connected according to this Instructions for Use.
Hazard	Patient and/or user can be harmed, device and/or other equipment can be damaged.
Prevention	<ul style="list-style-type: none"> ☞ The device has to be connected as specified in this Instructions for Use. ☞ Follow the connecting instructions given in the Instructions for Use of the MR System. ☞ Prior to examinations make sure all connections have been completed. ☞ Proper connection between the coil and the MR System needs to be checked in the user interface of the software prior to each exam. ☞ Examinations are not to be performed if the coil is inside the magnet and disconnected from the MR System.

If one or more auxiliary device is required to operate the product, follow the Instructions for Use of all devices used.

⚠ CAUTION	
Situation	Usage of equipment which is not MR safe or which is not specifically approved for usage with the device.
Hazard	Patient and/or user can be harmed, device and/or other equipment can be damaged.
Prevention	☞ Use only equipment which is MR safe and approved for combined usage with the device.

⚠ CAUTION	
Situation	Squeeze patient when closing the coil or/and when moving into magnet bore.
Hazard	Patient and/or user can be harmed, device and/or other equipment can be damaged.
Prevention	☞ Move, position and fix parts of coil with care. Move patient table with care at low speed.

7.4 Disconnecting the Coil

If not otherwise specified in the manual of the MR system, proceed as follows when removing the coil from the site of use after completing a measurement/examination:

1. Complete the MR measurement(s) on the control panel of the MR system;
2. Move the patient table out of the magnet bore;
3. Detach coil connections to the MR system.

	We recommend to clean the device and, if necessary, all auxiliary devices directly after use (see 7.5 Cleaning and Disinfection) and to check the integrity of all components - including labels.
---	---

7.5 Cleaning and Disinfection

Cleaning

Cleaning is an essential step before an effective disinfection. Cleaning is the physical removal of foreign material, e.g. dust, soil, organic material such as blood, secretions, excretions and microorganisms. Cleaning generally removes rather than kills microorganisms. Cleaning is accomplished with water, detergents and mechanical action.

⚠ CAUTION	
Situation	Wrong cleaning methods.
Hazard	Defective medical device.
Prevention	<ul style="list-style-type: none"> ☞ Use only commercially available mild household cleaning detergents, diluted in water following the guidelines of the manufacturer. ☞ Use a soft damp cloth. The device must not be immersed into liquids. Make sure no liquids can infiltrate. ☞ Do not use any rough or abrasive cleansing agents, which might damage the painting or the housing material.

Disinfection

Disinfection is the inactivation of disease producing microorganisms.

This device is classified as a non-critical medical product with regard to disinfection. Therefore an intermediate or low level disinfection is required.

	RAPID Biomedical recommends the use of an intermediate disinfectant with a scope of bactericide (including Mycobacterium), fungicide and virucide. (e.g. <i>Medipal</i> [®] <i>Chlorhexidine Wipes</i> ; <i>Bacillo</i> [®] <i>Wipes</i> ; <i>Kohrsolin</i> [®] <i>FF</i> or disinfectants listed by “Verbund für angewandte Hygiene e.V. (VAH)”, “Robert Koch Institut (RKI)” or “Centers for Disease Control and Prevention (CDC)” suitable for this application).
---	---

⚠ CAUTION	
Situation	Usage of an inadequate disinfection technique.
Hazard	Defective medical device.
Prevention	<ul style="list-style-type: none"> ☞ The disinfectant has to be an alcohol-based solution. ☞ Do not use any aldehyde- or phenol-based disinfectant solutions. ☞ The device must not be sterilized.

	<p>Cleaning and disinfection must comply with all applicable laws and regulations which have the force of law within the jurisdiction(s) in which the system is located.</p> <p>The device may only be cleaned and disinfected by authorized personnel.</p>
---	---

8 Special Technical Instructions for Using the Device

8.1 Performance / Quality Assurance

We recommend regular verification of the device's proper function by performing the Coil Quality Assurance test.

Coil Quality Assurance tests should be run by a GE Service Representative or a third party service provider. To have a Quality Assurance test run on a coil, please call your GE Service Representative or your third party service provider.

Please contact GE Healthcare at 800-582-2145 with any questions or concerns.

9 Appendix

9.1 Specifications







Device Name	3.0 T 16Ch Diagnostic Breast Coil		
Device Number (RAPID)	P-H16LE-030-01893		
MR Nuclei	1H		
Operating Frequencies	127.7 MHz		
MR System	GE 3.0 T MR Systems		
Field Strength of MR System	3.0 T		
RF Polarisation	linear		
Dimensions of Coil Housing	Length: 370 mm	Width: 540 mm	Height: 175 mm
Dimensions of left & right Cavity	Length: 160 mm	Width: 150 mm	Height: 130 mm
Location of Numbered Channels			
Length of Connecting Cable	900 mm		
Weight	5.9 kg		
Maximum allowed Patient Weight	Only restricted by the maximum load allowed for the patient table		
Application Environment		Indoor use only	
Operating Conditions:		+15°C to +24°C / +59°F to +75.2°F	
		30 % to 80 % RH	
		70 kPa - 107 kPa	
Transport & Storage Conditions:		-25°C to +60°C / -13°F to +140°F	
		5 % to 95 % RH	

Table 9-1: Product Specifications

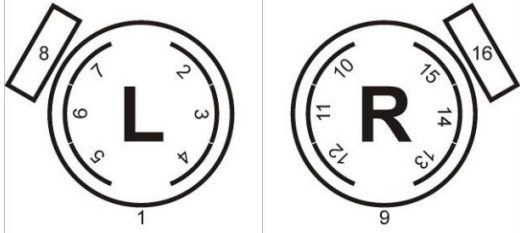
⚠ CAUTION	
Situation	Device is not operated within the limits of specified Operating Conditions.
Hazard	Patient and/or user can be harmed and the device and/or other equipment can be damaged.
Prevention	☞ Ensure that ambient conditions of the examination room (Temperature, Relative Humidity Air Pressure) are within limits of defined Operating Condition specifications.











9.2 Regulatory Information

Subject	Data
Manufacturer	RAPID Biomedical GmbH Kettelerstrasse 3-11 97222 Rimpfing, Germany Tel.: +49 (0)9365-8826-0 Fax: +49 (0)9365-8826-99 info@rapidbiomed.de www.rapidbiomed.de
Distributed by	GE Healthcare, LLC 3200 N Grandview Boulevard Waukesha, WI 53188 USA
UMDNS Code Universal Medical Device Nomenclature System	17-542
European Union	
Device Class	Class I - MDD Annex IX, Rule 12 / MDR Annex VIII, Rule 13
Initial CE marking	2017
USA	
Device Class	Class II - 21 CFR 892.1000
Device Code	MOS
Premarket Submission No.	K181948
Device Listing No.	D334567
Manufacturer FEI	3005049692
Importer/Distributor FEI	2183553
Canada	
Device Class	Class II - CMDR - SOR/98-282, Rule 7
Device Licence No.	102191
Manufacturer ID	140730
Importer/Distributor ID	117707
Turkey Importer Details/Türkiye İthalatçı Bilgileri:	
Importer/İthalatçı	GE Medical Systems Türkiye Ltd. Şti. Esentepe Mah. Harman Sok. No: 8 34394 Şişli-İstanbul Türkiye

Table 9-2: Regulatory Information

9.3 Labeling

 If labels are missing or have become illegible, the device must not be operated. The labelling may only be renewed or amended by RAPID Biomedical or by a representative of RAPID Biomedical.

Item	Symbol	Device Marking/Remarks
Manufacturer		RAPID Biomedical GmbH Kettelerstr. 3-11 97222 Rimpfing Germany
Distributed by		GE Medical Systems, LLC
Device Trade Names	n/a	3.0 T 16Ch Diagnostic Breast Coil
Device Reference Number		P-H16LE-030-01630
Device Serial Number		xxx (Three digits with leading zero)
Medical Device		
Unique Device Identifier		
GE Healthcare part #	n/a	5772248-2
Device Revision	REV.	xx
Country and Date of Manufacture (YEAR-MONTH-DAY)		YYYY-MM-DD
UDI Code (Sample)		(01)xxxxxxxxxxxx (11)xxxxxxxx (21)xxx
Device Type (T/R)		Receive-only Coil
RF Center of the Coil		(molded)
CE Label (Conforms to the essential requirements of Council Directive 93/42/EEC concerning Medical Devices).		
cTUVus Type Examination Canada / US		























<i>Item</i>	<i>Symbol</i>	<i>Device Marking/Remarks</i>
Follow the Instructions for Use		
Consult the Instructions for Use for Additional Relevant Safety Issues.		
Application Part Type BF.		
Class II according to IEC 61140.		
Electronic Instructions for Use (eIFU)		
Separate Collection of W aste E lectrical and E lectronic E quipment (WEEE Directive 2012/19/EU)		
System side connectors allowed		
Notice on coil connector (sticker)	n/a	never leave unplugged inside the bore

Table 9-3: Device Labeling

9.4 Symbols Glossary

Symbol	Source	Ref. No.	Symbol Title & Definition
	ISO 7000	5957	For indoor use only. To identify electrical equipment designed primarily for indoor use.
	ISO 7000	0632	Temperature limit. To indicate the maximum and minimum temperature limits at which the item shall be stored, transported or used.
	ISO 7000	2620	Humidity limitation. To indicate the acceptable upper and lower limits of relative humidity for transport and storage.
	ISO 7000	2621	Atmospheric pressure limitation. To indicate the acceptable upper and lower limits of relative humidity for transport and storage.
	ISO 7000	3082	Manufacturer. To identify the manufacturer of a product.
	ISO 7000	2497	Date of manufacture. The date can be a year, year and month, or year, month, day. The date shall be placed adjacent to the symbol. The date may for example be given as follows: 1996-06-12.
	IEC 60417	6049	Country of manufacture. To identify the country of manufacture of products. In the application of this symbol, the "CC" shall be replaced by either the two letter country code or the three letter country code defined in ISO 3166-1 (for Germany "DE"). Name of manufacturer and date of manufacture may be added adjacent to this symbol.
	ISO 7000	2493	Catalogue number. To identify the manufacturer's catalogue number, for example on a medical device or the corresponding packaging. The catalogue number shall be placed adjacent to the symbol
	ISO 7000	2498	Serial number. To identify the manufacturer's serial number, for example on a medical device or its packaging. The serial number shall be placed adjacent to the symbol.
	IEC 60417	6191	RF coil, transmit. To identify the radio frequency (RF) coil for transmit only.
	IEC 60417	6192	RF coil, transmit and receive. To identify the radio frequency (RF) coil for both transmit and receive.
	IEC 60417	6193	RF coil, receive. To identify the radio frequency (RF) coil for receive only.
	ISO 7010	M002	Refer to instruction manual/booklet. To signify that the instruction manual/booklet must be read.
	ISO 7000	0434A	Caution. To indicate that caution is necessary when operating the device or control close to where the symbol is placed, or to indicate that the current situation needs operator awareness or operator action in order to avoid undesirable consequences.
	IEC 60417	5840	Type B applied part. To identify a type B applied part complying with IEC 60601-1.













Symbol	Source	Ref. No.	Symbol Title & Definition
	IEC 60417	5333	Type BF applied part. To identify a type BF applied part complying with IEC 60601-1.
	IEC 60417	5172	Class II equipment. To identify equipment meeting the safety requirements specified for Class II equipment according to IEC 61140.
	Directive 2002/96/EC	Annex IV	Symbol for the marking of electrical and electronic equipment. The symbol indicating separate collection for electrical and electronic equipment consists of the crossed-out wheeled bin. The symbol must be printed visibly, legibly and indelibly.
	SJ/T 11364-2014	Chapter 5	People's Republic of China Electronic Standard: The logo is demonstrating the environmental protection characteristic of a product, namely that the product does not contain any hazardous substances.
	ISO 7000	1135	General symbol for recovery/recyclable. To indicate that the marked item or its material is part of a recovery or recycling process.
	ISO 7000	0621	Fragile, handle with care. To indicate that the contents of the transport package are fragile and the package shall be handled with care.
	ISO 7000	0623	This way up. To indicate correct upright position of the transport package.
	ISO 7000	0626	Keep away from rain. To indicate that the transport package shall be kept away from rain and in dry conditions.
	Directive 93/42/EEC	Annex XII	CE marking of Conformity for Medical Devices Class I
	Regulation (EU) 2017/745	Annex V	
	Directive 93/42/EEC	Annex XII	CE marking of Conformity with the number of the Notified Body to the right of the symbol for Medical Devices ≠ Class I
	Regulation (EU) 2017/745	Annex V	
	ISO 15223-1	5.7.7	Medical Device. Indicates the item is a medical device.
	ISO 15223-1	5.7.10	Unique Device Identifier. Indicates a carrier that contains Unique Device Identifier information.

Table 9-4: Symbols Glossary

9.5 List of Acronyms

Acronym	Explanation
AGB	Standard Terms and Conditions
C	Carbon
CD	Compact Disk
CFR	Code of Federal Regulations (USA)
CMDR	Canadian Medical Devices Regulations
EC	European Community
ECG	Electrocardiogram
EEC	European Economic Community
eIFU	Electronic Instructions for Use
EU	European Union
FID	Free Induction Decay
IEC	International Electrotechnical Commission
MDD	Council Directive 93/42/EEC
MDR	REGULATION (EU) 2017/745 OF THE EUROPEAN PARLIAMENT AND OF THE COUNCIL
MR	Magnetic Resonance
Na	Sodium
P-H16LE	Phased-Array, 1H, 16 channels, receive-only
P	Phosphorus
PN	Part Number
QA	Quality Assurance
REF	Reference Number (Part Number)
RF	Radio Frequency
RoHS	Restriction of Hazardous Substances
ROI	Region of Interest
Rx	Receive Function
SAR	Specific Absorption Rate
SN	Serial Number
SNR	Signal-to-Noise-Ratio
T/R	Transmit/Receive
Tx	Transmit Function
UDI	Unique Device Identification
WEEE	Waste of Electronical and Electrical Equipment